

SCOTSMAN

UNDERCOUNTER COMPACT CUBER WITH STORAGE

CSE60



24 HOUR VOLUME PRODUCTION

 Certified & rated in accordance with ARI standard 810-95	Air-Cooled	
	70°/50° lbs/kg.	ARI 90°/70° lbs./kg.
CSE60-1	69/31	54/25

DEPENDABLE PERFORMANCE IN ANY CONDITION:

- Produces up to 55 lbs. of crystal-clear, gourmet ice in 24 hours
- Stores up to 28 lbs.
- Energy Saving System that optimizes cycle efficiency and ice quality, while reducing energy consumption and cutting operating costs.
- Durable stainless steel construction.
- Power cord for quick installation.

WARRANTY *See your dealer for complete warranty details.*

- 3 years parts and labor on all components.
- 5 years parts on the compressor and condenser.



CRYSTAL CLEAR GOURMET CUBE

SIZE: 1"W x 1 1/8"H
DIAMETER: 1 1/4"

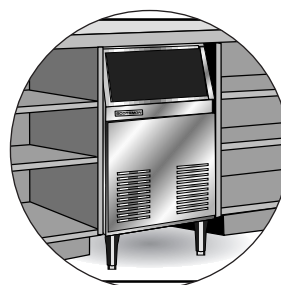

BUILT-IN CONVENIENCE

Under counter bar installation puts the ice where it is needed. Legs allow for cleaning below and aisle ventilation.

CERTIFIED
ISO
9001:2000

This product qualifies for the following listings:
  
Rated in accordance with ARI standard 810-95

Ice Machine Specifications

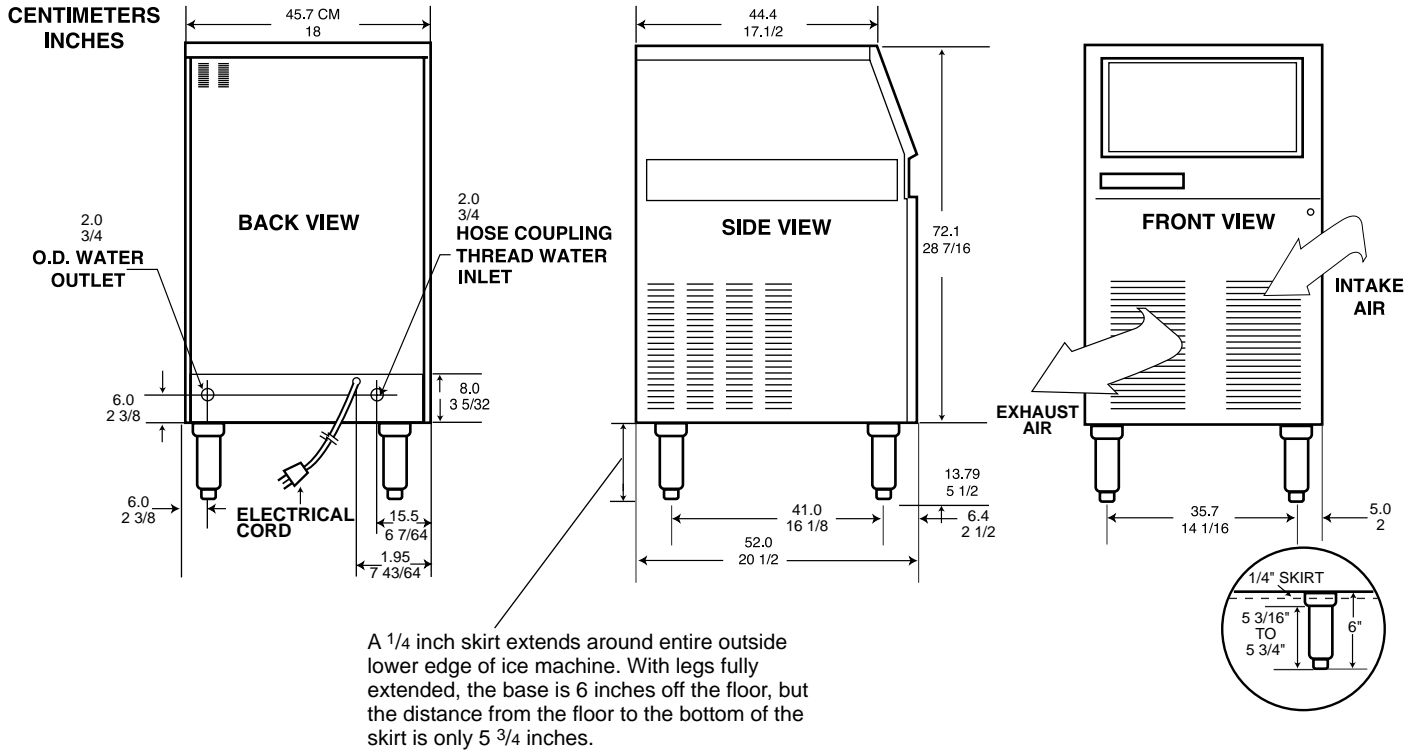

Installation Note: Allow 6" minimum space at back for utility connections

All models:		Dimensions W x D x H: without legs (Add 5 ^{3/16} " height for legs):			Unit: 18" x 20 ^{1/2} " x 28 ^{7/16} "			Shipping Carton: 24" x 21" x 31"			
Model Number	Condenser Unit	Bin* Capacity lbs./kg.	Basic Electrical Volts/Hz/Phase	Max. Fuse Size or HACR Circuit Breaker	Comp. HP	Circuit Wires	Min. Circuit Ampacity	Shipping Weight lbs./kg.	Power Consumption KWH/100 lbs. 90°F/70°F	Water Usage Gallons/100 lbs. Potable 90°F/70°F Condenser 90°F/70°F	
CSE60A-1A	AIR	28/12	115/60/1	15	1/4	2	CORD	105/48	17.3	49.0	-

*Bin capacity rated in accordance with ARI Standard 820-95.

All units with stainless steel finish.
Refrigerant: R-134a

LEGS SUPPLIED:
Four plastic legs screw into mounting plates on cabinet base. Provides 6" minimum height.

Scotsman's ice machines are not designed for outdoor installations. Scotsman remote condensers are designed for outdoor installations.

Machine requires voltage indicated on rating name plate. Failures caused by improper voltage are not considered factory defects. Extended periods of operation at temperatures exceeding limitations constitutes misuse under the terms of Scotsman Manufacturer's Limited Warranty, resulting in a loss of warranty coverage. Specifications and design are subject to change without notice.

Consult Your Local SCOTSMAN Representative At:

IMPORTANT OPERATING REQUIREMENTS:

	Minimum	Maximum
Air Temperatures	50°F (10°C)	100°F (37.7°C)
Water Temperatures	40°F (4.4°C)	100°F (37.7°C)
Water Pressures	20 PSIG	80 PSIG
Electrical Voltage	-5%	+10%

YOU'LL VALUE THE DIFFERENCE™

775 Corporate Woods Parkway • Vernon Hills, IL 60061 • 1-800-SCOTSMAN • Fax: (847) 913-9844
Visit our website at: www.scotsman-ice.com • E-mail: customer.service@scotsman-ice.com